



Linea Series Features - Soap and Faucet

- Sleek lines and curved-edged design pairs with Verge™ faucet model S53-3500
- Matching soap and faucet designs that integrate seamlessly with Bradley lavatories**
- Chrome-plated cast brass construction with optional in-stock PVD finishes*
- Sensing optimized to eliminate false activations and maximize battery life
- Vandal-resistant features include concealed sensor package, durable PVD finish options, and rotation-resistant gasket/washer
- Patents pending

Soap Key Features

- Foam or liquid soap options
- Top-fill individual and multi-feed tank options
- Utilizes universal bulk soap
- Vandal-resistant features
- Multi-station system supplies up to 6 soap dispensers
- Smart Sense System – Elegant translucent ring at the base of each dispenser gives a glowing indication of low battery, low soap, and overflow conditions
- Audible warning to stop filling before overflow occurs
- Spout reach designed to optimize handwashing space
- Touch-free infrared sensor-operated
- Power supply options to meet your application – battery pack or single AC plug-in adapter or AC adapter splitter assembly that accommodates up to 4 devices
- Cast brass spout construction with durable, environmentally-friendly finish*

Specification

Sleek lines and curved-edged design pairs with faucet model S53-3500 and integrates seamlessly with Bradley lavatories**. The dispenser is available with an individual or top fill multi-feed tank that is compatible with bulk foam or liquid soap. The multi-feed station system supplies soap to up to 6 soap dispensers. Activation through a touch-free infrared sensor that pairs seamlessly with Bradley's faucet dual sensor technology to eliminate false activations and maximize battery life. Dispenser shall feature chrome-plated cast brass construction with optional in-stock PVD finish. Vandal-resistant features include concealed sensor package, durable PVD finish options, and rotation-resistant gasket/washer.

Overall Spout Dimensions

- Height: 4" (102 mm)
- Width: 2¼" (57 mm)
- Depth: 6" (152 mm)

Capacity

- Individual tank: 70.5 oz (2080 ml) w/ 2850 estimated activations per tank
- Multi-feed tank: 166.5 oz (5026 ml) w/ 6930 estimated activations per tank
- Multi-feed can support up to 6 soap dispensers

Verify all rough-in dimensions prior to installation. Consult local and national codes. Conformity and compliance to local and national codes is the responsibility of the installer.



Product Compliance

- ADA / ICC ANSI A117.1, Citation 309.4
- UL electrical components
- CE electrical components

Finishes

Click on any color swatch to view as a larger image.

- Polished Chrome
- Brushed Black Stainless*
- Brushed Stainless*
- Brushed Bronze*
- Brushed Brass*
- Brushed Nickel*

*PVD Finishes, see PVD Finishes section.

* PVD Finishes

Physical Vapor Deposition is an intricate, environmentally friendly finishing process that molecularly bonds the finish to the faucet, creating a very hard, durable surface that will not corrode, discolor, or tarnish.

Compatible Bradley Products

- [Verge Faucet – Linea Series**](#)
- [Verge Lavatory Systems**](#)
- [ELX Lavatory Systems**](#)
- [LD-3010 Lavatory Systems**](#)
- [Multi-Feed Soap Tank Assembly](#)



Operation

Place hands under soap spout and hold for approximately 1.75 seconds. Spout will dispense liquid or foam soap depending on option selected.

- Allows 3 activations per 7.5 seconds.
Liquid: 0.65 ml to 0.80 ml per activation
Foam: 0.75 ml (liquid state) to 1.35 ml (foam state) per activation

Sensor Technology

Infrared sensor with 4–5" (102–127 mm) activation range† that pairs seamlessly with Bradley's faucet dual sensor technology to eliminate false activations and maximize battery life. See Sensing Dimensions diagram.

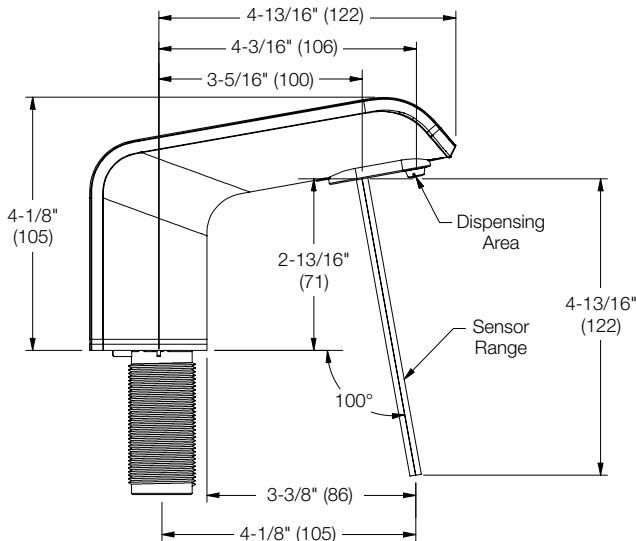

† A minimum of 5" (127 mm) clearance between the sensor and surface or bowl is needed to ensure proper function of the sensor. For information on specific applications, please contact Bradley Technical Service.

Indicator Lights

- Power ON (spout location): Flashes red for 1.2 seconds
- Power ON (multi-feed): Flashes green/red 3 times
- Soap dispense activation: Single flash green light
- Low power indication: Continuously flashing green light
- Low soap level: Flashes red when soap level is below 25% capacity
- Overflow condition: Steady red light with audible indication from buzzer lasts 2.5 seconds when fill level reaches 90% capacity

Verify all rough-in dimensions prior to installation.
Consult local and national codes. Conformity and compliance to local and national codes is the responsibility of the installer.

Power Source

Choose a power supply that meets your application: (Power source is not automatically included with Verge soap dispensers and must be chosen from the list below.)

- Individual battery pack† – each set of batteries can accommodate up to 140,000 cycles
- Individual AC power adapter option for 120V/230V for use on a single device

Ordered separately:

- AC adapter splitter assembly accommodates up to 4 devices. Use when desired to serve in combination of multiple devices (faucet, soap dispenser, and multi-feed soap tank assembly) and/or stations. (Electrical Plug Type B^{***})

† Quantity (4) D-cell batteries included with battery pack

Mounting

Verify all rough-in dimensions prior to installation. Mount dispenser in 1 $\frac{3}{8}$ " (35 mm) diameter hole in lavatory or countertop 1 $\frac{1}{2}$ " (38 mm) from edge of sink. Shank will accommodate a maximum counter thickness of 1 $\frac{1}{2}$ " (38 mm). **Accurate mounting is important to eliminating any sensor interference.**

Product Materials

- Spout assembly: Chrome-plated cast brass w/ optional in-stock PVD finish
- Control box: ABS plastic
- Battery box: ABS plastic
- Soap tank: Polypropylene

Soap Specifications

- Non-proprietary bulk soap (select foam or liquid)
- Liquid: Viscosity range of 100-5,000 cPs
- Foam: All-purpose foam hand soaps and antibacterial foam soaps containing PCMX and/or Triclosan

Vandal Resistance

- Concealed sensor package deters vandalism
- Durable PVD finish is scratch resistant
- Rotation-resistant gasket/washer
- Tamper resistant screw



Model	
6-3500	Verge Deck-Mounted Soap Dispenser – Linea Series
Required Selections (must select one from each category)	
Activation Type (select one)	
R	Infrared Sensor Operation
Soap Type (select one)	
F	Foam
L	Liquid
Fill System (select one)	
T	Single (Top fill at spout)
M	Multi-Feed (Shared Tank, Top-Fill Port)
Finish Type (select one)	
PC	<input type="checkbox"/> Polished Chrome
BB	<input type="checkbox"/> Brushed Black Stainless
BS	<input type="checkbox"/> Brushed Stainless
BZ	<input type="checkbox"/> Brushed Bronze
BR	<input type="checkbox"/> Brushed Brass
BN	<input type="checkbox"/> Brushed Nickel
Power Supply (select one)	
A14-029	AC Adapter - Electrical Plug Type B
A14-030	Battery Pack (includes 4x D-cell batteries)
NONE	No Power Supply Provided – must purchase A14-031 separately***

Additional Parts for Purchase (Purchased Separately)	
Feature	Part Number
*** AC Adapter Splitter Assembly accommodates up to 4 devices when desiring a combination of multiple devices (faucet, soap, & multi-feed soap tank assembly) and/or stations. (Electrical Plug Type B)	A14-031
Multi-Feed Soap Tank Assembly	6-SOAP-MFT

Verify all rough-in dimensions prior to installation. Consult local and national codes. Conformity and compliance to local and national codes is the responsibility of the installer.



6-3500 Verge™ Deck-Mounted Soap Dispenser – Linea Series

Dimensions – Single Top-Fill

(mm)

Note the dimension tolerances (bolded in the illustration below) before installation. Failure to adhere to these tolerances can cause the dispenser to work improperly.

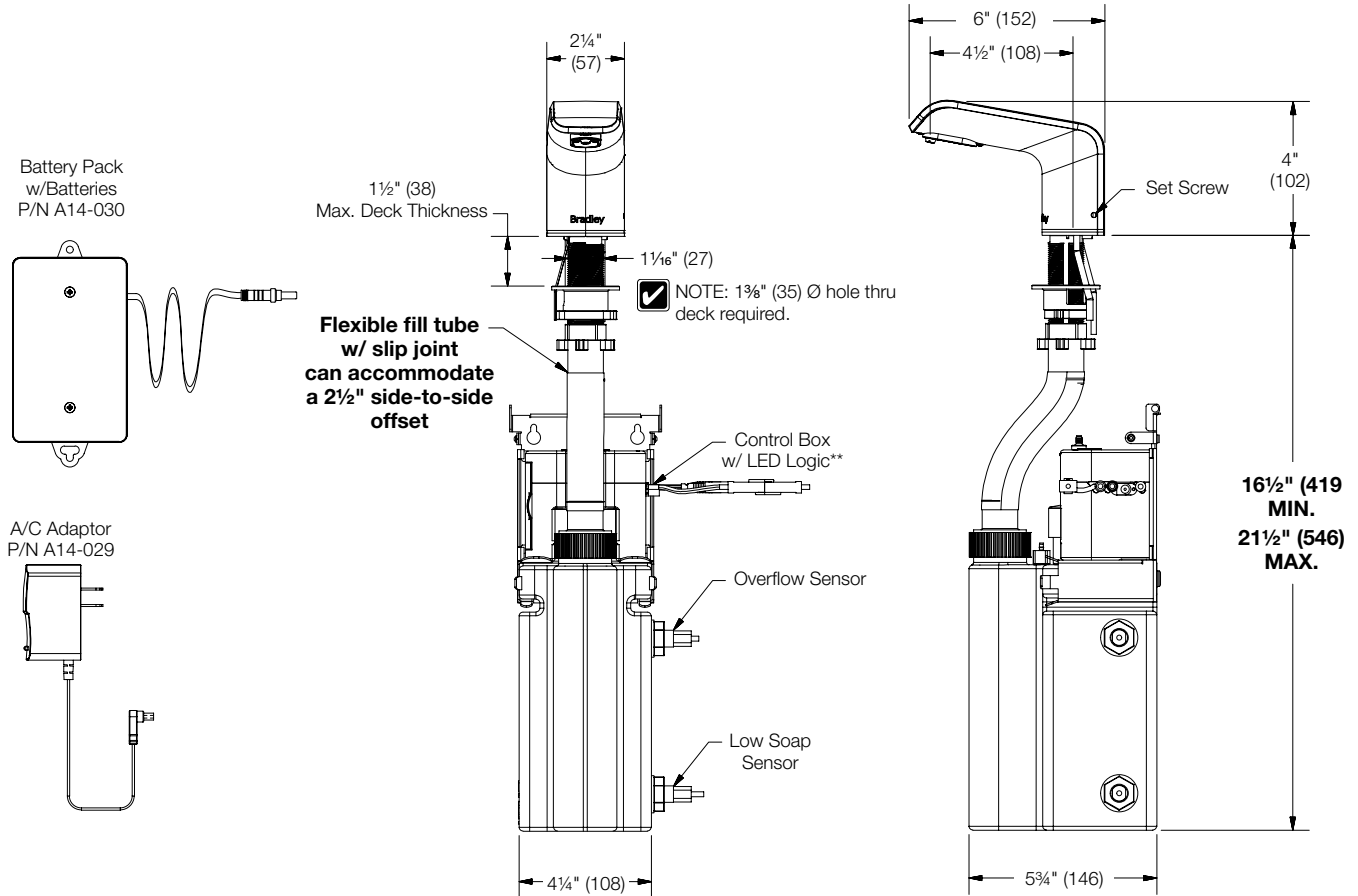

Verify all rough-in dimensions prior to installation. Consult local and national codes. Conformity and compliance to local and national codes is the responsibility of the installer.



Dimensions – Multi-Feed System - End Tank

(mm)

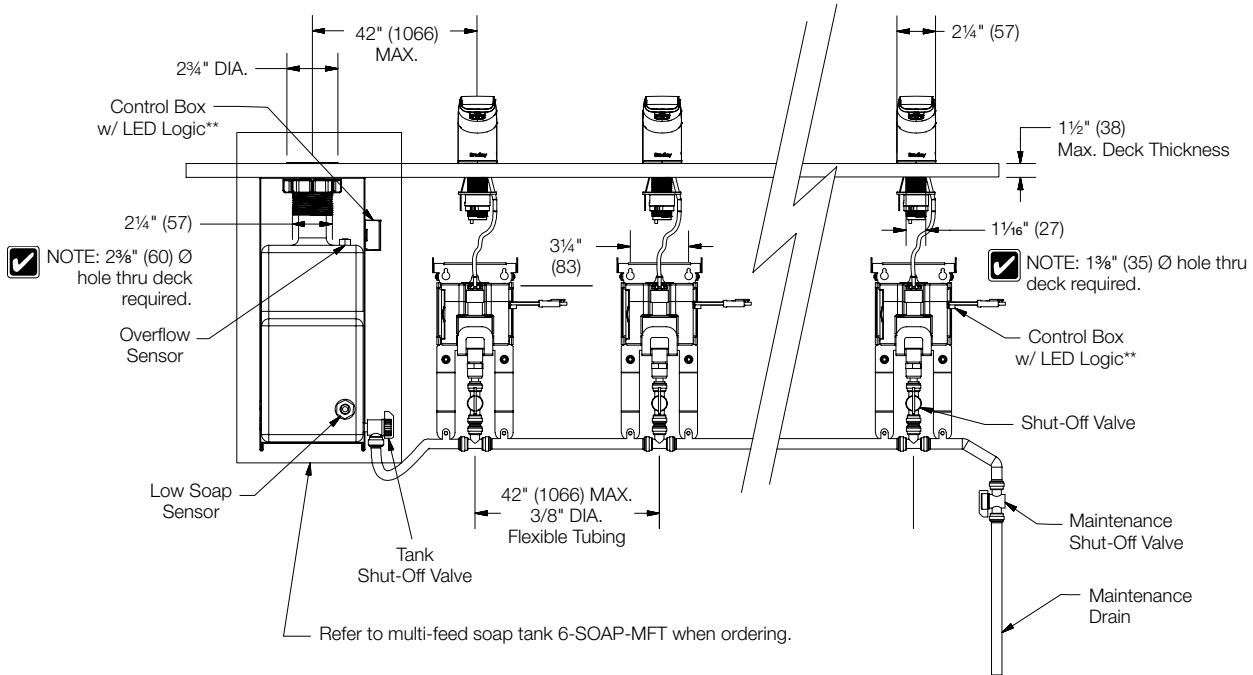

** NOTE: Battery pack or AC adaptor required.
 AC power source required to be within 54" (1371) of the control box.

A/C Adaptor
P/N A14-029

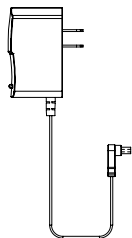

Battery Pack w/Batteries
P/N A14-030

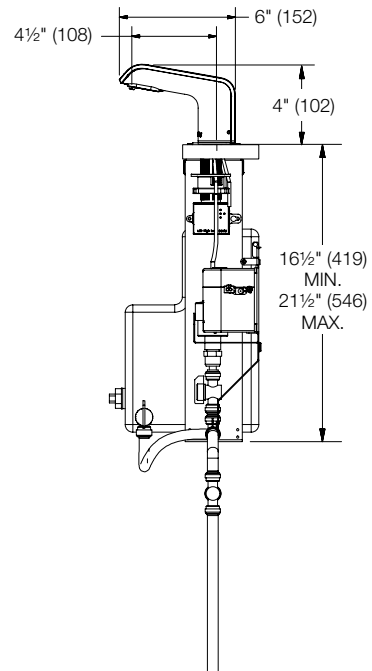
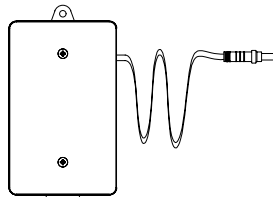

Verify all rough-in dimensions prior to installation.
 Consult local and national codes. Conformity and compliance to local and national codes is the responsibility of the installer.



Dimensions – Multi-Feed System - Mid Tank

(mm)

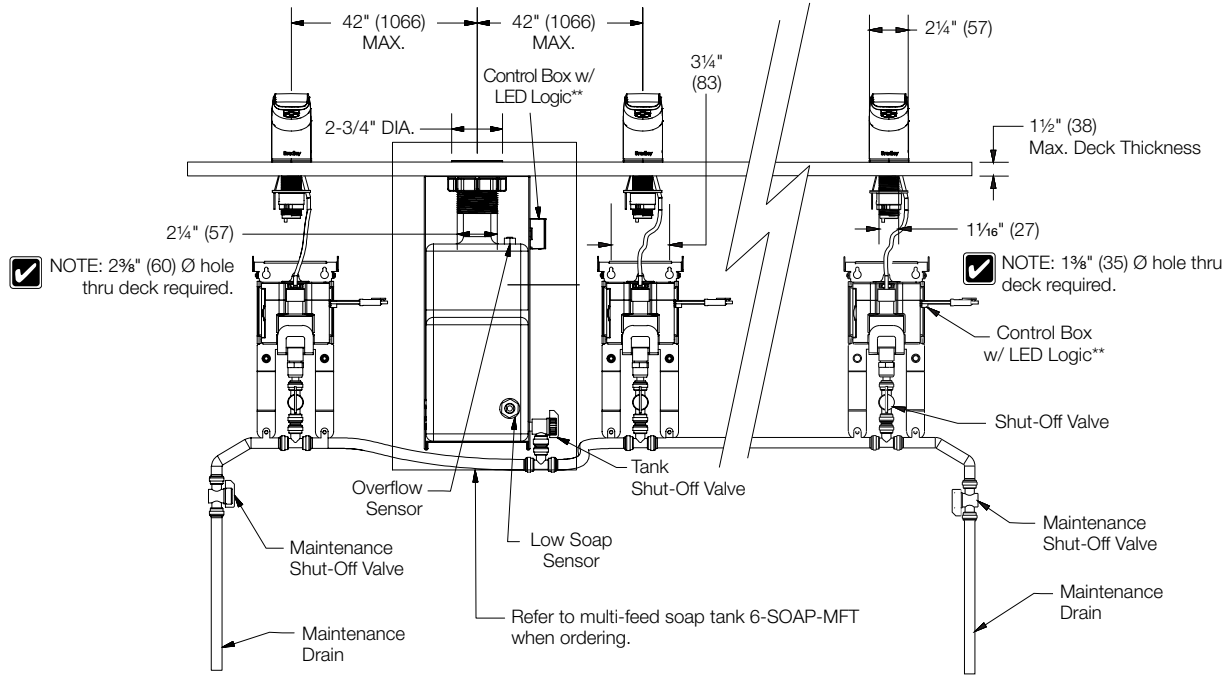

** NOTE: Battery pack or AC adaptor required.
 AC power source required to be within 54" (1371) of the control box.

A/C Adaptor
P/N A14-029

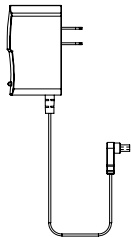

Battery Pack w/Batteries
P/N A14-030

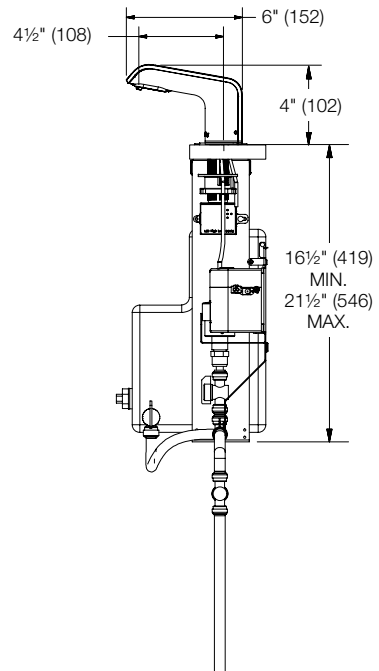
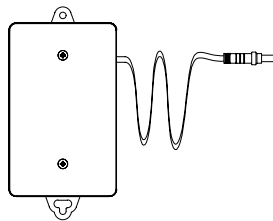

Verify all rough-in dimensions prior to installation.
 Consult local and national codes. Conformity and compliance to local and national codes is the responsibility of the installer.